



HV 100

High performance vector control inverter

Contents

Basic Specification

Feature

Industry-specific

Model and specifications

Core Algorithm

Open Loop General Proposal

High Performance Vector Control



Basic specifications

Voltage	Power
Single phase AC220V	0.4kw~37kw
Three phase AC220V	0.4kw~110kw
Three phase AC380V~440V	0.75kw~220kw

Based on listening and understanding of customers' requirement, HV100 supports full range of input voltage, complete functions for different countries and applications.

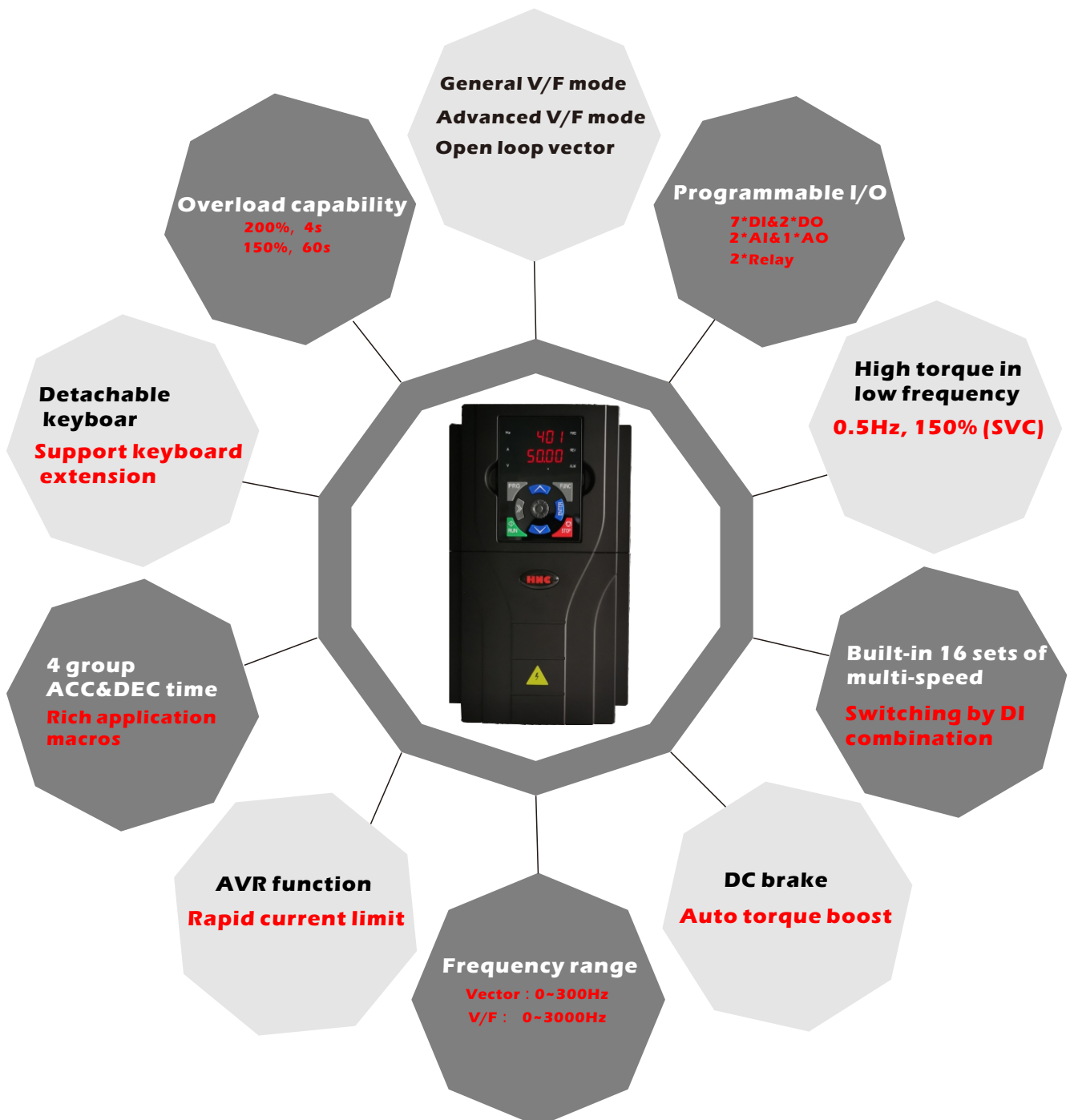

High performance vector control inverter

Product advantages

All Macros for Special Applications



Monitor operating status via PC, optimize, modify, back up and copy data parameters

Built-in swing frequency function

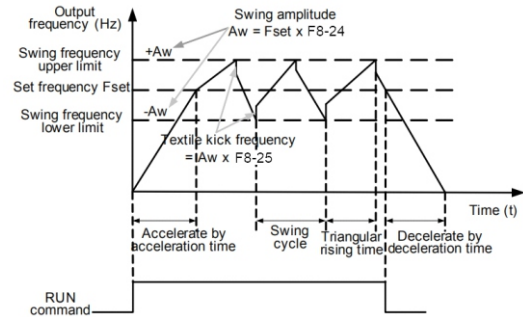

Textile & chemical fiber industries which need to traverse and winding function

Copy parameter by LCD Keyboard



Easy copy of parameters between devices

Multiple communication control methods as options



Can be matched with various mainstream control systems

Long-life design

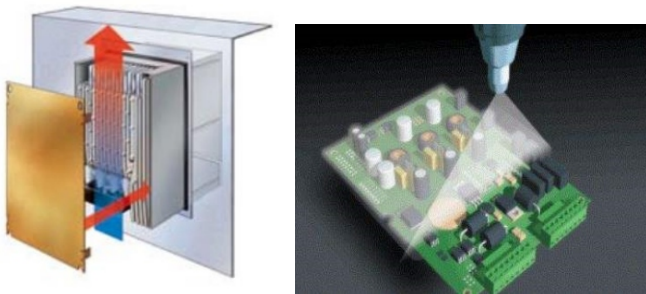

The independent air duct design and three layers of protective paint ensure that the product can run stably for a long time in harsh environments

Multiple EMC solutions

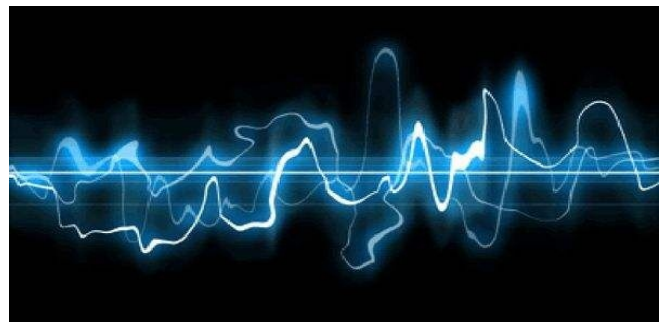

We offer complete EMC solutions including:
Built-in EMC filter, External filter and reactor
Built-in filter capacitor
External input / output reactor, input / output filter, harmonic filter, sine filter, etc.

Model Definition

HV 100 - 7R5 G 3				
①		②	③	④
① HV 100 Series Inverter			③ Code	Inverter Type
			G	General Type
			P	Fan / Pump Type
② NO.	Adaptative		④ Code Inverter Type	
R75	0.75kW		1	Single phase 220V
1R5	1.5kW		2	Three phase 220V
011	11kW		3	Three phase 380V
015	15kW			

HV 100 Rated current output table

Model	Input current (A)	Output current (A)	Adaptive motor	
			(KW)	(HP)
G1 input voltage range: Single-phase AC220V±15%, 50 / 60 Hz				
HV100-R40G1	5.4	2.4	0.4	0.5
HV100-R75G1	8.2	4.5	0.75	1
HV100-1R5G1	14	7	1.5	2
HV100-2R2G1	23	10	2.2	3
HV100-004G1	30	16	3.7	5
HV100-5R5G1	43	20	5.5	7.5
HV100-7R5G1	57	30	7.5	10
HV100-011G1	85	42	11	15
HV100-015G1	113	55	15	20
HV100-018G1	130	70	18.5	25
HV100-022G1	156	80	22	30
HV100-030G1	208	110	30	40
HV100-037G1	251	130	37	50
G2 input voltage range: Three-phase AC220V±15%, 50 / 60 Hz				
HV100-R40G2	3.4	2.4	0.4	0.5
HV100-R75G2	5	4.5	0.75	1
HV100-1R5G2	7.8	7	1.5	2
HV100-2R2G2	10.5	10	2.2	3
HV100-004G2	16.6	16	3.7	5
HV100-5R5G2	26	20	5.5	7.5
HV100-7R5G2	35	30	7.5	10
HV100-011G2	46.5	42	11	15
HV100-015G2	62	55	15	20
HV100-018G2	75	70	18.5	25
HV100-022G2	85	80	22	30
HV100-030G2	115	110	30	40
HV100-037G2	135	130	37	50
HV100-045G2	165	160	45	60
HV100-055G2	210	200	55	75
HV100-075G2	275	270	75	100
HV100-093G2	325	320	93	125
HV100-110G2	385	380	110	150

High performance vector control inverter

Frequency inverter model	Input current (A)	Output current (A)	Adaptive motor	
G3 input voltage range: Three-phase AC 380~440 (-15%~+10%), 50 / 60 Hz				
HV100-R75G3	3.4	2.5	0.75	1
HV100-1R5G3	5	3.7	1.5	2
HV100-2R2G3	5.8	5	2.2	3
HV100-004G3	10.5	9	4	5
HV100-5R5G3	14.6	13	5.5	7.5
HV100-7R5G3	20.5	17	7.5	10
HV100-011G3	26	25	11	15
HV100-015G3	35	32	15	20
HV100-018G3	38.5	37	18.5	25
HV100-022G3	46.5	45	22	30
HV100-030G3	62	60	30	40
HV100-037G3	80	75	37	50
HV100-045G3	94	90	45	60
HV100-055G3	128	110	55	75
HV100-075G3	160	150	75	100
HV100-093G3	190	176	93	125
HV100-110G3	225	210	110	150
HV100-132G3	265	253	132	180
HV100-160G3	310	300	160	220
HV100-185G3	345	340	185	260
HV100-200G3	385	380	200	280
HV100-220G3	430	420	220	300

Specification

Items	Description			
Rated Input	Rating Voltage	Three-phase (G3/G4 series) 380V-480V, 50/60HZ		
	Frequency	Single&Three-phase (G1/G2 series) 220 V: 50/60 Hz		
Allowable range of voltage	Three-phase (G3 series)	: AC 380~440 (-15%~+10%)		
	Three-phase (G4 series)	: AC 460~480 (-15%~+10%)		
Output	Voltage	G1/G2 series; 0 ~ 220V, G3 series; 0 ~ 440 V, G4 series; 0 ~ 480 V		
	Frequency	Low frequency mode: 0 ~ 300 Hz; high frequency mode: 0 ~ 3000 Hz		
	Overload capacity	G type machine: 110% long-term; 150% 1 minute ;200% 4 seconds P type machine: 105% long-term ;120% 1 minute; 150% 1 second		
Control mode	V/F control, advanced V/F control, V/F separation control and PG-free current vector control			
Control characteristic	Frequency setting Resolution	Analog end input	0.1% of the maximum output frequency	
		Digital settings	0.01Hz	
	Frequency accuracy	Analog input	Within 0.2% of the maximum output frequency	
		Digital input	Set the output frequency within 0.01%	
	V/F control	V/F curve (voltage frequency characteristic)	The reference frequency can be set arbitrarily from 0.5 Hz to 3000 Hz, and the multi-point V/F curve can be set arbitrarily. You can also choose a variety of fixed curves such as constant torque, torque reduction 1, torque reduction 2 and square torque	
		Torque boost	Manual setting: 0.0 ~ 30.0% of rated output Automatic boost: automatically determine the boost torque according to the output current and motor parameters	
Automatic current and voltage limiting		Whether in acceleration, deceleration or stable operation, the motor stator current and voltage can be automatically detected, which can be suppressed within the allowable range according to the unique algorithm to minimize the possibility of system fault tripping		
Control characteristic	Sensorless vector control	voltage frequency characteristic	Automatically adjust output voltage-frequency ratio according to motor parameters and unique algorithm	
		Torque characteristic	Starting torque: 150% rated torque at 3.0Hz (VF control) 150% rated torque at 1.0Hz (advanced VF control) 150% rated torque at 0.5Hz (without PG current vector control) Running speed steady-state accuracy: $\leq \pm 0.2\%$ rated synchronous speed Speed fluctuation: $\leq \pm 0.5\%$ rated synchronous speed Torque response: $\leq 20\text{ms}$ (without PG current vector control)	
		Self-determination of motor parameters	Without any restriction, the parameters can be automatically detected under static and dynamic conditions to obtain the best control effect	
		Current and voltage suppression	Full-range current closed-loop control, completely avoiding current impact, with perfect overcurrent and overvoltage suppression function	
	Running undervoltage suppression	Especially for users with low grid voltage and frequent fluctuation of grid voltage, the system can maintain the longest possible operation time according to the unique algorithm and residual energy allocation strategy even in the range below the allowable voltage		
Typical function	Multi speed and Swing frequency operation	16-stage programmable multi-stage speed control and multiple operation modes are optional. Swing frequency operation: preset frequency and center frequency can be adjusted, and state memory and recovery after power failure		
	PID control RS485 communication	Built-in PID controller (preset frequency). Standard configuration RS485 communication function, multiple communication protocols can be selected, with linkage synchronous control function		
	Frequency setting	Analog input	DC voltage 0 ~ 10 V, DC current 0 ~ 20 mA (upper and lower limits are optional)	
		Digital input	keypad setting, RS485 interface setting, UP/DOWN terminal control, and various combination settings with analog input can also be made.	
Output signal	Digital output	2 Y-terminal open collector outputs and two programmable relay outputs (TA/TB/TC), with up to 61 functions		

High performance vector control inverter

Specification

Items		Description	
	Rated	Analog output 2 analog signals are output, and the output range can be flexibly set between 0 ~ 20mA or 0 ~ 10V, which can realize the output of physical quantities such as set frequency and output frequency	
	Automatic voltage stabilizing operation	According to the needs, three modes can be selected: dynamic voltage stabilization, static voltage stabilization and non-voltage stabilization, so as to obtain the most stable operation effect	
	Acceleration and deceleration Time setting	0.1s ~ 3600.0min can be set continuously, and S-type and linear mode can be selected	
	Brake	Energy consumption Brake	Energy consumption braking starting voltage, return difference voltage and energy consumption braking rate can be continuously adjusted
		Direct current Brake	Starting frequency of DC braking during shutdown: 0.00 ~ [000.13] upper limit frequency Braking time: 0.0 ~ 100.0 s; Braking current: 0.0% ~ 150.0% rated current
		Magnetic flow Brake	0 ~ 100 0: invalid
	Low noise operation	The carrier frequency is continuously adjustable from 1.0 kHz to 16.0 kHz to minimize the noise of the motor	
	Revolving speed tracking speed Restart facility	It can realize the smooth restart and instantaneous stop restart of the motor in operation	
	Counter	One internal counter is convenient for system integration	
	Operating function	Upper and lower limit frequency setting, frequency jump operation, reverse operation limit, slip frequency compensation, RS485 communication, frequency increment and decrement control, fault self-recovery operation, etc	
Display	keypad display	Running State	Output frequency, output current, output voltage, motor speed, set frequency, module temperature, PID setting, feedback amount, analog input and output, etc
		Alarm Content	The last six fault records, the record of six operation parameters such as output frequency, set frequency, output current, output voltage, DC voltage and module temperature during the last fault trip.
Protection function		Over-current, over-voltage, under-voltage, module failure, electronic thermal relay, overheating, short circuit, input and output phase failure, abnormal tuning of motor parameters, internal memory failure, etc.	
Environment	Ambient temperature	-10°C ~ +40°C (the ambient temperature is 40°C ~ 50°C, please use it at a reduced level)	
	Ambient humidity	5% ~ 95% RH, no water condensation	
	Surrounding environment	Indoor (no direct sunlight, corrosion, flammable gas, oil mist, dust, etc.)	
Structure	Altitude	1000 meters above the use of derating, every 1000 meters up derating 10%	
	Protection grade	IP20	
	Cooling mode	Air-cooled with fan control	
Installation method		Wall mounted, cabinet mounted	

Overall dimensions of the whole machine

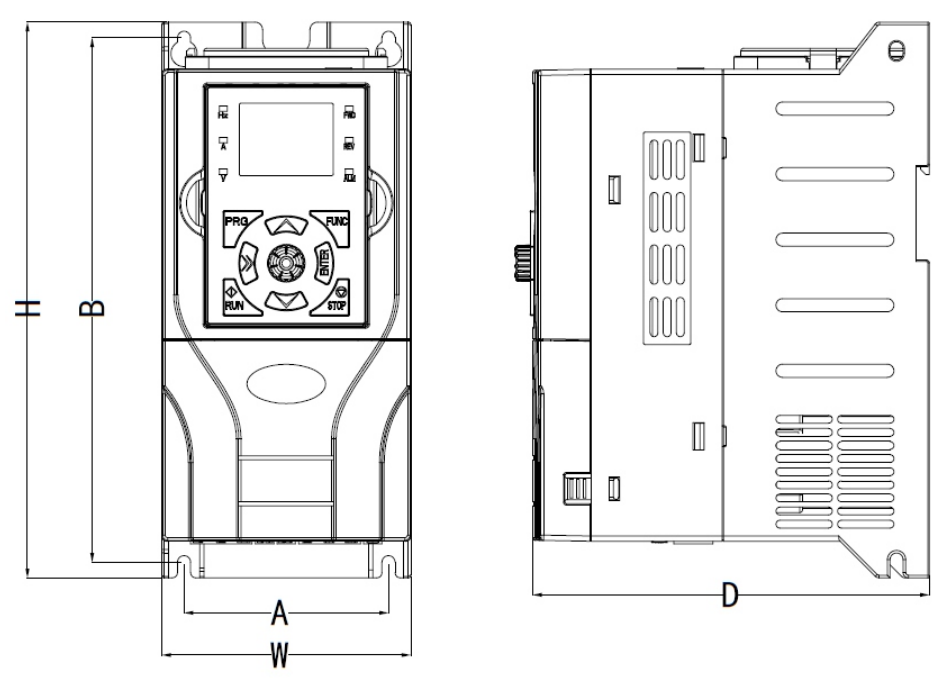

Plastic shell size diagram

Model	Mounting (mm)		Exterior(mm)			Hole (mm)
	A	B	H	W	D	
HV100-R40G1/2	78	200	212	95	154	5
HV100-1R5G1/2						
HV100-R75G1/2						
HV100-2R2G1/2						
HV100-R75G3						
HV100-1R5G3						
HV100-2R2G3						
HV100-004G3						
HV100-004G1/2	129	230	240	140	180.5	5
HV100-5R5G1/2						
HV100-5R5G3						
HV100-7R5G3						
HV100-011G3	188	305	322	205	199	6
HV100-7R5G1/2						
HV100-011G1/2						
HV100-015G1/2						
HV100-015G3						
HV100-018G3						
HV100-022G3						
HV100-030G3						

High performance vector control inverter

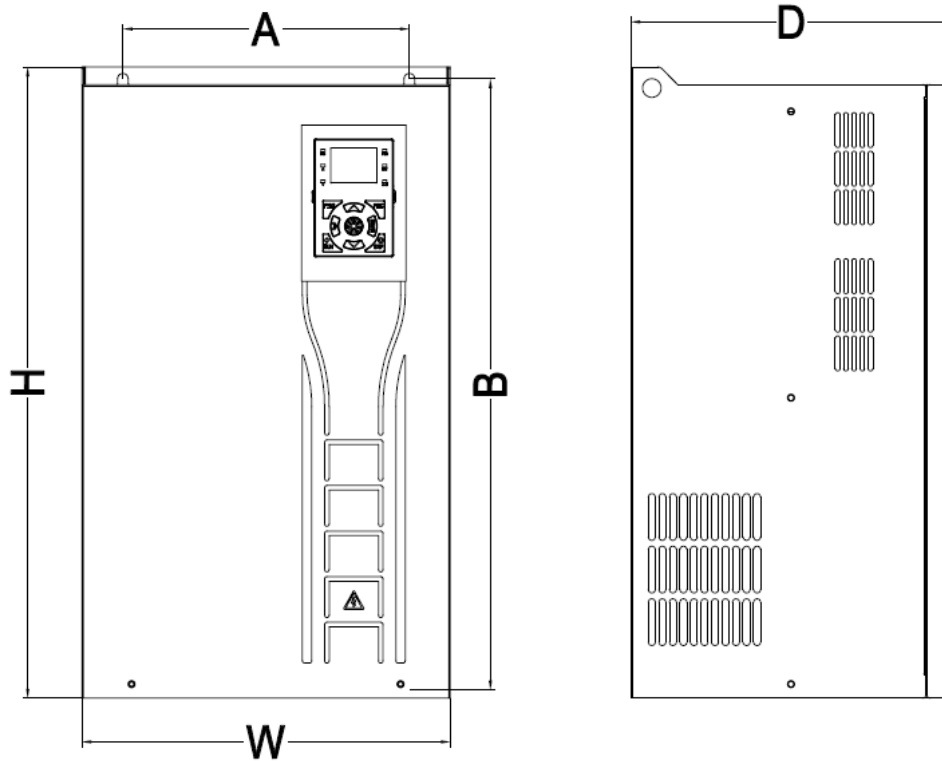

Metal shell size diagram

Model	Mounting (mm)		Exterior(mm)			Hole (mm)
	A	B	H	W	D	
HV100-018G1/2	195	465	490	270	205	6
HV100-022G1/2						
HV100-037G3						
HV100-045G3						
HV100-030G1/2	245	523	540	315	275	9
HV100-037G1/2						
HV100-055G3						
HV100-075G3						
HV100-045G2	270	555	575	350	305	9
HV100-055G2						
HV100-093G3						
HV100-110G3						
HV100-075G2	300	720	740	400	335	9
HV100-132G3						
HV100-160G3						
HV100-093G2						
HV100-110G2	370	795	820	480	360	11
HV100-185G3						
HV100-200G3						
HV100-220G3						

Standard wiring diagram of frequency inverter

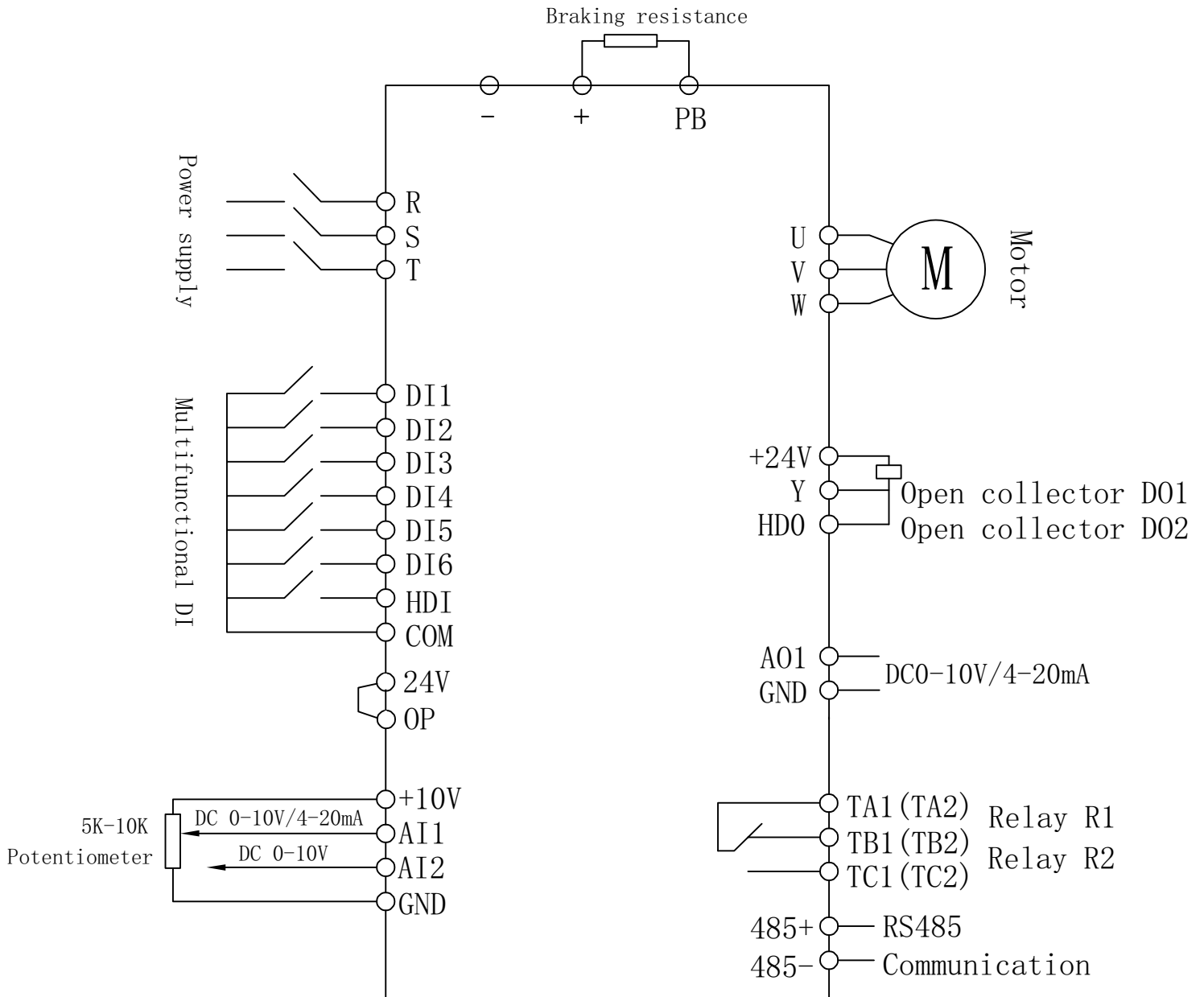



HNC
Electric

HNC ELECTRIC LIMITED is a company dedicated to the development and production of intelligent industrial automation solutions based on national strategic needs.

Supported by its outstanding electrical and electronic technology and strong control technology, it provides control, display, drive and system solutions and other related products and services to customers worldwide.

With 25 years of hard work, we have developed and produced professional CNC systems, industrial robots, servo drives, servo motors, reducers, inverters, PLCs, HMIs, etc.

In more than 50 countries and regions around the world, we have established a comprehensive agent system and after-sales service system. In the future, we will, as always, provide more professional services for global industrial automation.

HNC
Electric



Thanks for choosing HNC product
Any technique support, please feel to contact our support team

URL: www.hncelectric.com
Email: support@hncelectric.com