



# Bar Graphic Temperature Indicators

## KN-1000B Series PRODUCT MANUAL

**For your safety, read and follow the considerations written in the instruction manual, other manuals and Autonics website.**

The specifications, dimensions, etc. are subject to change without notice for product improvement. Some models may be discontinued without notice.

### Safety Considerations

- Observe all 'Safety Considerations' for safe and proper operation to avoid hazards.
- ⚠ symbol indicates caution due to special circumstances in which hazards may occur.

**⚠ Warning** Failure to follow instructions may result in serious injury or death

- 01. Fail-safe device must be installed when using the unit with machinery that may cause serious injury or substantial economic loss. (e.g. nuclear power control, medical equipment, ships, vehicles, railways, aircraft, combustion apparatus, safety equipment, crime/disaster prevention devices, etc.)**  
Failure to follow this instruction may result in personal injury, economic loss or fire.
- 02. Do not use or store the unit in the place where flammable/explosive/corrosive gas, high humidity, direct sunlight, radiant heat, vibration, impact or salinity may be present.**  
Failure to follow this instruction may result in explosion or fire.
- 03. Install on a device panel to use.**  
Failure to follow this instruction may result in fire or electric shock.
- 04. Do not connect, repair, or inspect the unit while connected to a power source.**  
Failure to follow this instruction may result in fire or electric shock.
- 05. Check 'Connections' before wiring.**  
Failure to follow this instruction may result in fire.
- 06. Do not disassemble or modify the unit.**  
Failure to follow this instruction may result in fire or electric shock.

**⚠ Caution** Failure to follow instructions may result in injury or product damage

- 01. Use the unit within the rated specifications.**  
Failure to follow this instruction may result in fire or product damage
- 02. Use a dry cloth to clean the unit, and do not use water or organic solvent.**  
Failure to follow this instruction may result in fire or electric shock.
- 03. Keep the product away from metal chip, dust, and wire residue which flow into the unit.**  
Failure to follow this instruction may result in fire or product damage.
- 04. Check the polarity of the measurement input before wiring.**  
Failure to follow this instruction may result in explosion or fire.

### Cautions during Use

- Follow instructions in 'Cautions during Use'. Otherwise, it may cause unexpected accidents.
- For connecting the power, use the crimp terminal (M3.5, max. 7.2 mm).
- 24 VDC power supply should be insulated and limited voltage/current or Class 2, SELV power supply device.
- Keep away from high voltage lines or power lines to prevent inductive noise. Do not use near the equipment which generates strong magnetic force or high frequency noise.
- Install a power switch or circuit breaker in the easily accessible place for supplying or disconnecting the power.
- Use twisted pair wire for communication line.
- This unit may be used in the following environments.
  - Indoors (in the environment condition rated in 'Specifications')
  - Altitude Max. 2,000 m
  - Pollution degree 2
  - Installation category II

## Ordering Information

This is only for reference, the actual product does not support all combinations.  
For selecting the specified model, follow the Autonics website .

**K N - 1 ① ② ③ B**

### ① Alarm output

0: No mark  
2: 2 alarm  
4: 4 alarm

### ② Option output

0: No mark  
1: PV Transmission  
4: Communication

### ③ Power supply

0: 100-240 VAC 50/60 Hz  
1: 24 VDC

## Product Components

- Product
- Instruction manual
- Bracket ×2
- Unit sticker ×1
- Connector (KN-10□□B: ×3, KN-12□□B: ×4, KN-140□□B: ×4, KN-141□□B: ×5, KN-144□□B: ×5)

## Software

Download the installation file and the manuals from the Autonics website.

### ■ DAQMaster

DAQMaster is comprehensive device management program. It is available for parameter setting, monitoring.

## Specifications

Series	KN-1000B Series	
	AC voltage	DC voltage
Power supply	100 - 240 VAC ~ 50/60 Hz	24 VDC≒
Permissible voltage range	90 to 110 % of rated voltage	
Power consumption	≤ 6 VA	≤ 4 W
Sampling period	• Thermocouple, RTD: 250 ms • Analog: 100 ms	
Input specification	Refer to 'Input Type and Using Range'.	
Digital input	Contact	• ON: ≤ 2 kΩ • OFF: ≥ 90 kΩ
	Non contact	• Residual voltage: ≤ 1.0 V • leakage current: ≤ 0.03 mA
	Outflow current	≈ 0.2 mA
Option output	Alarm	• 2 point relay: 250 VAC ~ 3 A 1c • 4 point relay: 250 VAC ~ 1 A 1a
	PV transmission	ISOLATED DC 4-20 mA (Load resistance: ≤ 600 Ω)
	RS485 comm.	Modbus RTU
Display type	7 Segment (red), Graph bar (green)	
Alarm output Hysteresis	1 to 999 digit	
Relay life cycle	Mechanical	• 2 point: ≥ 10,000,000 operations • 4 point: ≥ 20,000,000 operations
	Electrical	• 2 point: ≥ 100,000 operations (load resistance: 250 VAC ~ 3 A) • 4 point: ≥ 500,000 operations (load resistance: 250 VAC ~ 1 A)
Dielectric strength	Between the charging part and the case: 2,000 VAC ~ 50/60 Hz for 1 min	
Vibration	0.75 mm amplitude at frequency of 5 to 55 Hz in each X, Y, Z direction for 2 hours	
Insulation resistance	≥ 100 MΩ (500 VDC≒ megger)	
Noise immunity	±2 kV square shaped noise (pulse width 1 μs) by noise simulator	
Memory retention	≈ 10 years (non-volatile semiconductor memory type)	
Ambient temperature	-10 to 50 °C, storage: -20 to 60 °C (no freezing or condensation)	
Ambient humidity	35 to 85%RH, storage: 35 to 85%RH (no freezing or condensation)	
Certification	CE	
Unit weight (packaged)	≈ 182 g (≈ 304 g)	

## Communication Interface

### ■ RS485

Comm. protocol	Modbus RTU
Maximum connection	31 units
Synchronous method	Asynchronous
Comm. method	Two-wire half duplex
Comm. effective range	≤ 1,200 m (≤ 700 m recommended)
Comm. speed	9,600 (default) / 4,800 / 2,400 / 1,200 bps (parameter)
Data bit	8 bit (fixed)
Parity bit	None (fixed)
Stop bit	1 bit (fixed)

## Input Type and Using Range

Input type	Display	Using range (°C)	Using range (°F)		
Thermo-couple	K (CA)	E C . E 1	-200 to 1350	-328 to 2,462	
	K (CA)	E C . E 2	-199.9 to 999.9	-328 to 1,832	
	J (IC)	E C - J	-199.9 to 800.0	-328 to 1,472	
	E (CR)	E C - E	-199.9 to 800.0	-328 to 1,472	
	T (CC)	E C - E	-199.9 to 400.0	-199.9 to 752.0	
	R (PR)	E C - r	0 to 1,750	32 to 3,182	
	B (PR)*	E C - b	0 to 1,800	212 to 3,272	
	S (PR)*	E C - s	0 to 1,750	32 to 3,182	
	N (NN)*	E C - n	-200 to 1,300	-328 to 2,372	
	C (W5)*	E C - C	0 to 2,300	32 to 4,172	
	L (IC)*	E C - L	-199.9 to 900.0	-328 to 1,652	
	U (CC)*	E C - U	-199.9 to 400.0	-199.9 to 752.0	
	Platinel II*	E C - P	0 to 1,390	32 to 2,534	
	RTD	Cu50Ω*	C U 5 0	-199.9 to 200.0	-199.9 to 392.0
		Cu100Ω*	C U 1 0	-199.9 to 200.0	-199.9 to 392.0
JPt100Ω		J P E 1	-199.9 to 600.0	-328 to 1,112	
DPt50Ω		d P E 5	-199.9 to 600.0	-328 to 1,112	
DPt100Ω		d P E 1	-199.9 to 850.0	-328 to 1,530	
Analog	Current	0.00 - 20.00 mA	R n R 1	-1,999 to 9,999 (Display range is variable according to decimal point position.)	
		4.00 - 20.00 mA	R n R 2		
	Voltage	-50.0 - 50.0 mV	R n u 1		
		-199.9 - 200.0 mV	R n u 2		
		-1.000 - 1.000 V	R - u 1		
	-1.00 - 10.00 V	R - u 2			

\* Above input types which have the \* mark are displayed only in Input specification expansion. Refer to 'Mode Setting' to check how to enter the mode.

### ■ Display accuracy

Input type	Using temperature	Display accuracy
Thermocouple	At room temperature (25 °C ± 5 °C)	PV ± 0.2% F.S. ± 1 digit
RTD	Out of room temperature range	• Thermocouple below -100 °C: (PV ± 0.4% F.S.) ± 1 digit
Analog	Out of room temperature range	PV ± 0.3% F.S. ± 1 digit

\* In case of TC-T, TC-U, ±2.0 °C will be added to the degree standard.

## Unit Descriptions

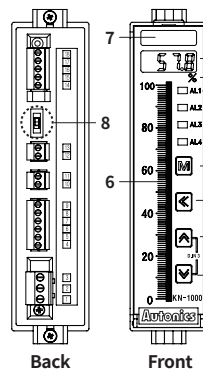

### 1. Display part (red)

Run mode: Displays PV (Present value).  
Setting mode: Displays parameter and setting value.

### 2. Unit sticker part

### 3. Alarm output indicator

Turns ON when the alarm output is ON.

### 4. [M] key

Used to enter parameter set mode, move to parameters, save SV and return to RUN mode.

### 5. [◀], [▶], [▼] key

Used to enter and change parameter setting value.

### 6. Bar graph (green)

Refer to 'Bar Graph'.

### 7. Space for recognizing device by user

### 8. Selection switch for input specification



0 - 20 mA: Select it for DC 0 (4) - 20 mA input (default)

-1 - 10 V: Select it for -1 - 10 VDC≒ input

RTD / TC / mV / ±1 V: Select it for Thermocouple, RTD, ±1 V, mV input

\* The setting of input type selection switch and the setting value of input type parameter must be the same to display the proper measurement value.

## Dimensions

- Unit: mm, For the detailed drawings, follow the Autonics website.
- Below is based on KN-1000B model.

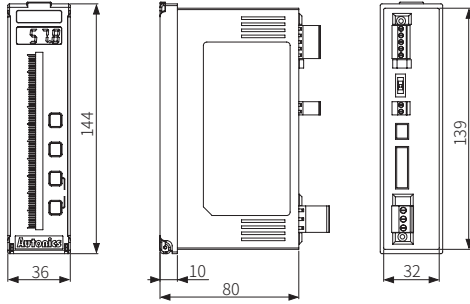

### Bracket

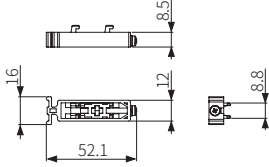

### Panel cut-out



## Connections

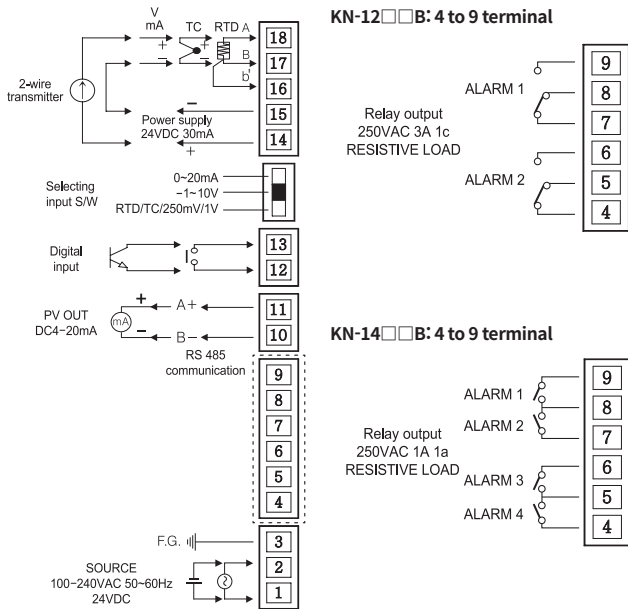

## Errors

Display	Description	Troubleshooting
b U r n	Flashes when input sensor is disconnected or sensor is not connected.	Check input sensor status.
H H H H	Flashes when PV is higher than input range.	When input is within the rated input range, this display disappears.
L L L L	Flashes when PV is lower than input range.	
E r r	Flashes when there is an error of setting value	Check the setting condition and reset.

## Mode Setting

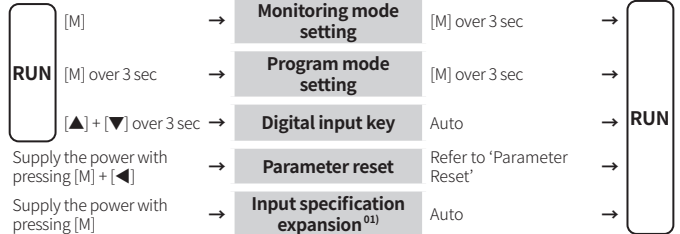

01) Refer to 'Communication Parameter Setting' for checking the details about communication.

## Parameter Reset

- Supply power while pressing [M]+ [◀] keys, CLR turns ON.
- Press [M] key for parameter reset mode.
- Change the setting value to YES by pressing the [▲], [▼] keys.
- Press the [M] key to reset all parameter values as default and to return to run mode.

## Parameter Setting

- Some parameters are activated/deactivated depending on the model or setting of other parameters. Refer to the descriptions of each item.
- [M] key: Move to next item after saving
- [◀] key: Select parameter / Move digits
- [▲], [▼] key: Select parameter / Change setting value
- Return to the RUN mode without saving when there is no key input for more than 30 seconds.

### Monitoring mode

Parameter	Display	Default	Setting range	Condition
1-1 AL1 alarm temperature	AL 1	099.9		2-15/17/19/21 AL-1/2/3/4 alarm operation: AT1, AT2
1-2 AL2 alarm temperature	AL 2	099.9 (4 alarm model) 000.1 (2 alarm model)	[Alarm output model] Sensor input: within using range Analog Input: L-SC ≤ AL□ ≤ H-SC	
1-3 AL3 alarm temperature	AL 3	000.1	[4 alarm output model]	
1-4 AL4 alarm temperature	AL 4	000.1	Same as 1-1/2 AL1/2 alarm temperature	
1-5 High peak	H.P.E.L	----	Check only (not available to set) Displays high/low peak (Max./Min. input) value	-
1-6 Low peak	L.P.E.L	----	• Initial high/low peak is saved after 2 sec from supplying the power. • Value reset: [▲] + [▼] key over 3 sec in 1-5/6 High/Low peak parameter	

## Program mode

Parameter	Display	Default	Setting range	Condition
2-1 Input specification	<i>I n - P</i>	<i>R, R, R, I</i>	Refer to 'Input Type and Using Range'.	-
2-2 Temperature unit	<i>U n i t</i>	<i>°C</i>	°C, °F	2-1 Input specification: Thermocouple, RTD
2-3 Low limit input	<i>L - r G</i>	<i>0 0 0 0</i>	Using range low limit ≤ L-RG ≤ using range high limit - 10% of F.S.	2-1 Input specification: Analog
2-4 High limit input	<i>H - r G</i>	<i>2 0 0 0</i>	L-RG + 10% of F.S. ≤ H-RG ≤ using range high limit	
2-5 Decimal point	<i>d P</i>	<i>0 0</i>	0.0, 0.00, 0.000, 0	
2-6 Low limit scale	<i>L - S C</i>	<i>0 0 0 0</i>	-1,999 ≤ L-SC < H-SC ≤ 9,999 • When setting '2-24 Input special function: TUF' L-SC: -760.0, H-SC: 0 to 9,999	
2-7 High limit scale	<i>H - S C</i>	<i>1 0 0 0</i>		
2-8 Input correction <sup>(01)</sup>	<i>I n - b</i>	<i>0 0 0 0</i>	-999 to 999, L-SC < IN-B < H-SC	2-1 Input specification: Thermocouple, RTD
			-999 to 999, L-SC ≤ L-RG ≤ IN-B ≤ H-RG ≤ H-SC	2-1 Input specification: Analog
2-9 Bar graph display low limit scale	<i>L - b 5</i>	<i>0 0 0 0</i>	• Input: Thermocouple, RTD Input range low limit ≤ L-BS ≤ (H-BS-1) (L-BS+1) ≤ H-BS ≤ Input range high limit	-
2-10 Bar graph display high limit scale	<i>H - b 5</i>	<i>1 0 0 0</i>	• Input: Analog L-SC ≤ L-BS ≤ (H-SC-1) (L-SC+1) ≤ H-BS ≤ H-SC	-
2-11 Bar graph display method	<i>b B r</i>	<i>F, b B r</i>	F.BAR: Full bar, C.BAR: Center bar	-
2-12 4 mA transmission output scale	<i>L o U t</i>	<i>0 0 0 0</i>	[Transmission output model] • Input: Thermocouple, RTD: Within input range	-
2-13 20 mA transmission output scale	<i>H o U t</i>	<i>1 0 0 0</i>	• Input: Analog L-SC ≤ L.OUT ≤ 10% of F.S. ≤ H.OUT ≤ H-SC	-
2-14 Input and transmission output extension <sup>(02)</sup>	<i>E x t</i>	<i>5 P</i>	[Transmission output model] Setting value   Input range   Transmission output range 0P   No extension   4 - 20 mA 5P   ±5% extension   3.2 - 20.8 mA 10P   ±10% extension   2.4 - 21.6 mA	2-1 Input specification: Analog
2-15 AL1 alarm operation	<i>A L - 1</i>	<i>R t I R</i> <i>□ □ □</i>	[Alarm output model] □□□ AT0: Off AT1: Absolute high limit alarm AT2: Absolute low limit alarm SBA: Sensor break alarm	-
2-16 AL1 alarm option			A: Standard alarm B: Alarm latch C: Standby D: Alarm latch and standby sequence • Enter to option setting: Press [◀] key in 2-15 AL-1 alarm operation.	-
2-17 AL2 alarm operation	<i>A L - 2</i>	<i>R t I R</i> (4 alarm model)	[Alarm output model] Same as 2-15/16 AL1 alarm operation/option	-
2-18 AL2 alarm option		<i>R t 2 R</i> (2 alarm model)		-
2-19 AL3 alarm operation	<i>A L - 3</i>	<i>R t 2 R</i>		-
2-20 AL3 alarm option			[4 alarm output model] Same as 2-15/16 AL1 alarm operation/option	-
2-21 AL4 alarm operation	<i>A L - 4</i>	<i>R t 2 R</i>		-
2-22 AL4 alarm option				-
2-23 Alarm output hysteresis	<i>A - H y</i>	<i>0 0 1</i>	001 to 999	2-15/17/19/21 AL-1/2/3/4 alarm operation: AT1, AT2
2-24 Input special function	<i>I n S F</i>	<i>L i n</i>	LIN: Linear, ROOT: Root, SQAR: Square, TUF: Two unit function	2-1 Input specification: Analog
2-25 Input digital filter	<i>ñ R u F</i>	<i>0 y</i>	01 (OFF) to 16 • It does not affect the display cycle.	-
2-26 Digital input terminal <sup>(03)</sup>	<i>d i - t</i>	<i>H o L d</i>	HOLD <sup>(04)</sup> : Hold, ZERO: Zero-point adjustment, AL.RE*: Alarm reset *[Alarm output model]	* 2-16/18/20/22 AL1/2/3/4 Alarm option: B, D
2-27 Digital input key <sup>(03)</sup>	<i>d i - k</i>	<i>H o L d</i>		
2-28 Sensor break alarm output	<i>b U r n</i>	<i>o F F</i>	[Transmission output model] OFF: 4 mA, ON: 20 mA	-
2-29 Comm. address	<i>A d d r</i>	<i>0 1</i>	[Communication output model] 01 to 99	-
2-30 Comm. speed	<i>b R U d</i>	<i>9 6 0 0</i>	[Communication output model] 9600, 4800, 2400, 1200 bps	-
2-31 Lock	<i>L o c k</i>	<i>o F F</i>	OFF LOC1: Program mode lock (check only) Monitoring mode unlock LOC2: Checking and setting program mode lock Monitoring mode setting lock (check only)	-

01) When '2-24 input special function' parameter is set to 'TUF', the function corrects the atmospheric pressure input value.

02) Extension is not allowed below 0 mA and 0 V. ±1 V and 10 V inputs cannot be set to 10P.

03) When changing functions, change after releasing the signal being input to the terminal.

04) The hold function is maintained even when a temperature error occurs.

## Communication Parameter Setting

### RUN status group

Address	Parameter	Display	Output range
300001 (0000)	Display value output	-	Display value
			[2 alarm output model]: 0 to 3 [4 alarm output model]: 0 to 15
			Output value   Alarm status
			Alarm 1   Alarm 2   Alarm 3   Alarm 4
			0   OFF   OFF   OFF   OFF
			1   ON   OFF   OFF   OFF
			2   OFF   ON   OFF   OFF
			3   ON   ON   OFF   OFF
			4   OFF   OFF   ON   OFF
			5   ON   OFF   ON   OFF
			6   OFF   ON   ON   OFF
			7   ON   ON   ON   OFF
			8   OFF   OFF   OFF   ON
			9   ON   OFF   OFF   ON
			10   OFF   ON   OFF   ON
			11   ON   ON   OFF   ON
			12   OFF   OFF   ON   ON
			13   ON   OFF   ON   ON
			14   OFF   ON   ON   ON
			15   ON   ON   ON   ON

### Monitoring mode setting group

Address	Parameter	Display	Setting range
302001 (07D0) to 302004 (07D3)	AL1 to 4 alarm temperature	<i>R L 1</i> -	[Alarm output model] Thermocouple, RTD input: Within input specification, Analog input: L-SC to H-SC
302005 (07D4)	High peak	<i>H P E P</i>	-
302006 (07D5)	Low peak	<i>L P E P</i>	-

### Program mode setting group

Address	Parameter	Display	Setting range				Condition	
			Value	Display	Value	Display	Value	Display
301001 (03E8)	Input specification	<i>I n - P</i>	0	<i>E C P 1</i> (6)	<i>E C - b</i> (12)	<i>E C - P</i> (18)	<i>R ñ R 1</i> (19)	
			1	<i>E C P 2</i> (7)	<i>E C - 5</i> (13)	<i>E U 5 0</i> (14)	<i>R ñ R 2</i> (20)	
			2	<i>E C - U</i> (8)	<i>E C - n</i> (14)	<i>E U 1 0</i> (20)	<i>R ñ u 1</i> (21)	
			3	<i>E C - E</i> (9)	<i>E C - C</i> (15)	<i>U P E 1</i> (21)	<i>R ñ u 2</i> (22)	
			4	<i>E C - t</i> (10)	<i>E C - L</i> (16)	<i>d P t 5</i> (22)	<i>A - u 1</i> (23)	
			5	<i>E C - r</i> (11)	<i>E C - U</i> (17)	<i>d P t 1</i> (23)	<i>A - u 2</i> (24)	
								• The setting values in '(')' parenthesis can be set only in 'Input specification expansion' mode. Refer to 'Mode Setting'.
301002 (03E9)	Temperature unit	<i>U n i t</i>	0: °C, 1: °F					
301003 (03EA)	Low limit Input	<i>L - r G</i>	Same as parameter setting range					
301004 (03EB)	High limit Input	<i>H - r G</i>	Same as parameter setting range					
301005 (03EC)	Decimal point	<i>d P</i>	0: 0, 1: 0.0, 2: 0.00, 3: 0.000					
301006 (03ED)	Low limit scale	<i>L - S C</i>	Same as parameter setting range					
301007 (03EE)	High limit scale	<i>H - S C</i>	Same as parameter setting range					
301008 (03EF)	Bar graph display low limit scale	<i>L - b 5</i>	Same as parameter setting range					
301009 (03F0)	Bar graph display high limit scale	<i>H - b 5</i>	Same as parameter setting range					
301010 (03F1)	Bar graph display method	<i>b B r</i>	0: Full bar, 1: Center bar					
301011 (03F2)	4 mA transmission output scale	<i>L o U t</i>	Same as parameter setting range					
301012 (03F3)	20 mA transmission output scale	<i>H o U t</i>	Same as parameter setting range					
301013 (03F4)	Input and transmission output extension	<i>E x t</i>	0: 0 %, 1: 5 %, 2: 10 %					Same as each parameter setting condition
301014 (03F5) to 301017 (03F8)	AL 1 to 4 alarm operation	<i>A L - 1</i> - <i>A L - 4</i>	1: Absolute high limit alarm, 2: Absolute low limit alarm, 3: Sensor break alarm, 4: Off					
301018 (03F9) to 301021 (03FC)	AL 1 to 4 alarm option	<i>A L - 1</i> - <i>A L - 4</i>	10: Standard alarm, 11: Alarm latch, 12: Standby sequence, 13: Alarm latch and standby sequence, 14: No alarm (not settable)					
301022 (03FD)	Alarm output hysteresis	<i>A - H y</i>	Same as parameter setting range					
301023 (03FE)	Input special function	<i>I n S F</i>	0: Linear, 1: Root, 2: Square, 3: Two unit function					
301024 (03FF)	Input correction	<i>I n - b</i>	Same as parameter setting range					
301025 (0400)	Input digital filter	<i>ñ R u F</i>	Same as parameter setting range					
301026 (0401)	Digital input terminal	<i>d i - t</i>	0: Alarm reset, 1: Hold, 2: Zero-point adjustment					
301027 (0402)	Digital input key	<i>d i - k</i>						
301028 (0403)	Sensor break alarm output	<i>b U r n</i>	0: 20 mA, 1: 4 mA					
301029 (0404)	Comm. address	<i>A d d r</i>	Same as parameter setting range					
301030 (0405)	Comm. speed	<i>b R U d</i>	0: 9600, 1: 4800, 2: 2400, 3: 1200					
301031 (0406)	Lock	<i>L o c k</i>	0: OFF, 1: LOC1, 2: LOC2					

## Function: Bar Graph

### Display method setting

It is possible to set in bar graph display method parameter.

#### Full bar

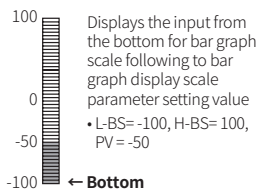

#### Center bar

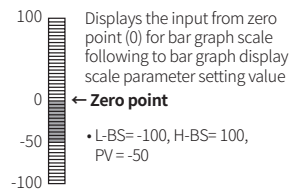

### Alarm display in bar graph

When setting or occurring the alarm, it displays the status by the bar graph. It is possible to check the alarm status. When setting alarm value, the bar LED for this alarm value turns ON. When alarm occurs, the bar LED for this alarm value flashes.

- If alarm set value is out of bar graph scale when setting the value or in RUN mode, this value does not display in bar graph.

#### Monitoring mode: setting alarm value

The bar LED for alarm setting value flashes. When alarm set is complete, the bar LED for this alarm value turns ON.

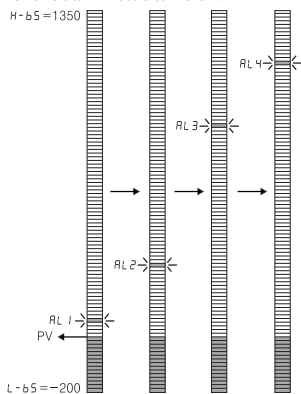

#### Run mode: alarm display

All set alarm values are displays and when it is alarm value, the bar LED for this alarm value flashes.

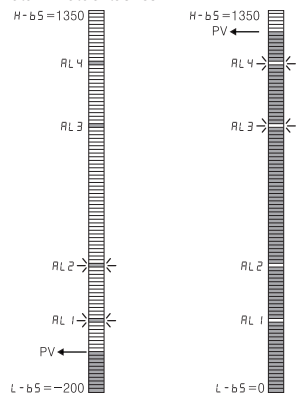

- The bar LED for the alarm value flashes.
- AL1/2: Low limit alarm
- AL3/4: High limit alarm

### Scale value relation

Below is relation example of input specification, high/low limit input, high/low limit scale, bar graph display high/low limit scale, 4/20 mA transmission output scale when using 4 to 20 mA input specification.

Refer to 'Parameter Setting' for the details about setting range and condition.

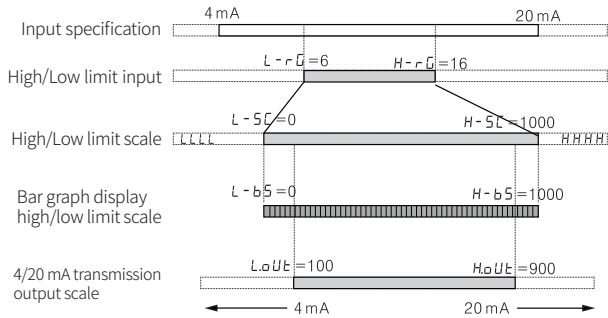

## Function: Input Special Function

When selecting analog input, this function is to display the calculated actual value by square, root ( $\sqrt{\quad}$ ), or two unit function (TUF) as display value.

Name	Function	Graph	Applications
Linear	Outputs as input value	$Y = AX + B$	Standard characteristics. Input for linearity.
Root	Outputs the rooted ( $\sqrt{\quad}$ ) input value	$Y = A\sqrt{X} + B \quad (X \geq 0)$ $Y = 0 \quad (X < 0)$	Used for measuring flows by pressure signal.
Square	Outputs the squared input value	$Y = A(X)^2 + B \quad (X > 0)$ $Y = -A(X)^2 + B \quad (X < 0)$	Used for outputting differential pressure by flow signal.
Two unit	Display the pressure of under atmospheric pressure (0) as mmHg unit		<ul style="list-style-type: none"> <li>• Compound pressure input &lt; atmospheric pressure: Displayed in mmHg</li> <li>• Compound pressure input ≥ atmospheric pressure: Displayed in kg/cm²</li> </ul> Atmospheric pressure is based on 0 kg/cm². Atmospheric pressure value can be calibrated by using the 'Digital input: zero-point adjustment' function and additionally adjusted by using the 'input correction' function.

## Function: Input Digital Filter

Moving average digital filter is able to stably display and output the noise from input line and irregular signals as software.

- Display cycle is same when executing moving average digital filter.

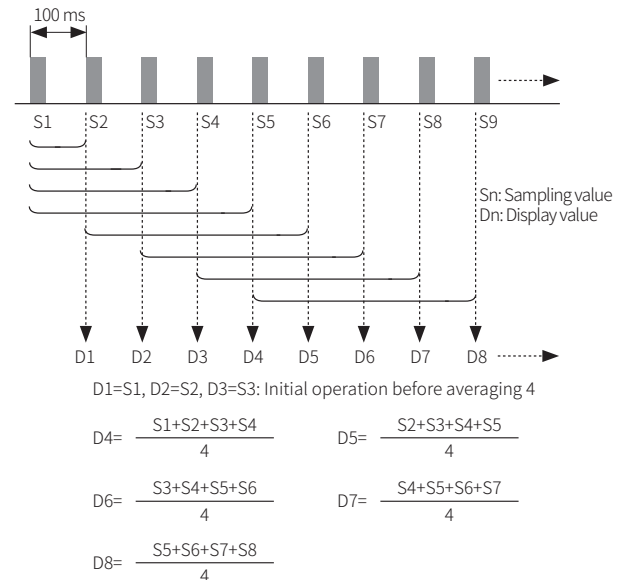

## Function: High / Low-limit scale value

This function is to display setting of particular high / low-limit value in order to display high / low-limit value of measured input.  
If measured inputs are a and b and particular values are A and B, it will display a = A, b = B as below graphs.

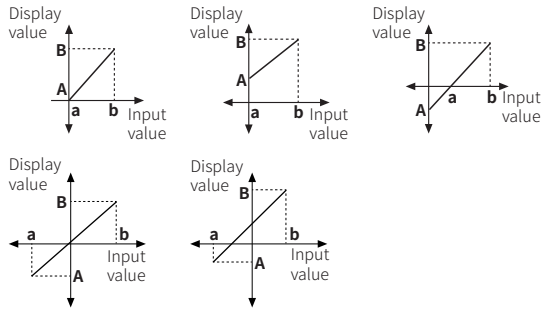

## Function: Alarm

888.8

Alarm operation Alarm option

Set both alarm operation and alarm option by combining. Each alarm operates individually in two alarm output models. When the current temperature is out of alarm range, alarm clears automatically.

### ■ Operation

• H: Alarm output hysteresis

Mode	Name	Alarm operation	Description
R E 0	-	-	No alarm output
R E 1	Absolute value high limit	OFF $\downarrow$ H $\uparrow$ ON PV 90°C	If PV is higher than the absolute value, the output will be ON.
		OFF $\downarrow$ H $\uparrow$ ON PV 110°C	
R E 2	Absolute value low limit	ON $\uparrow$ H $\downarrow$ OFF PV 90°C	If PV is lower than the absolute value, the output will be ON.
		ON $\uparrow$ H $\downarrow$ OFF PV 110°C	
S b R	Sensor break	-	It will be ON when it detects sensor disconnection.

### ■ Option

Mode	Name	Description	Condition of reapply
R	Standard alarm	If it is an alarm condition, alarm output is ON. If it is a clear alarm condition, alarm output is OFF.	-
b	Alarm latch	If it is an alarm condition, alarm output is ON and maintains ON status.	-
C	Standby sequence	When power is supplied and it is an alarm condition, this first alarm condition is ignored and from the second alarm condition, standard alarm operates.	Power ON
d	Alarm latch and standby sequence	If it is an alarm condition, it operates both alarm latch and standby sequence. When power is supplied and it is an alarm condition, this first alarm condition is ignored and from the second alarm condition, alarm latch operates.	

## Segment Table

The segments displayed on the product indicate the following meanings. It may differ depending on the product.

7 Segment	11 Segment	12 Segment	16 Segment
0 0 i I	0 0 i I	0 0 i I	0 0 I I
1 1 j J	1 1 j J	1 1 j J	1 1 j J
2 2 k K	2 2 k K	2 2 k K	2 2 k K
3 3 l L	3 3 l L	3 3 l L	3 3 l L
4 4 m M	4 4 m M	4 4 m M	4 4 m M
5 5 n N	5 5 n N	5 5 n N	5 5 n N
6 6 o O	6 6 o O	6 6 o O	6 6 O O
7 7 p P	7 7 p P	7 7 p P	7 7 p P
8 8 q Q	8 8 q Q	8 8 q Q	8 8 q Q
9 9 r R	9 9 r R	9 9 r R	9 9 r R
A A s S	A A s S	A A s S	A A s S
b B t T	b B t T	b B t T	b B t T
C C u U	C C u U	C C u U	C C u U
d D v V	d D v V	d D v V	d D v V
E E w W	E E w W	E E w W	E E w W
F F x X	F F x X	F F x X	F F x X
G G y Y	G G y Y	G G y Y	G G y Y
H H z Z	H H z Z	H H z Z	H H z Z